

**Do you need a reliable  
cost effective solar pumping system?**

**We'll look no further...**



## **WATERBOY 4HRSS Solar Pump**

*"How's this for ticking all your boxes"*

- Peace of mind*
- Reliability*
- Dependability*
- User friendly*

### **CHARACTERISTICS**

- *lift up to 140m*
- *flow rate up to 2.8m<sup>3</sup>/h*
- *simple installation*
- *maintenance-free*
- *high reliability and life expectancy*

### **APPLICATIONS**

- *Drinking water supply*
- *Livestock watering*
- *Irrigation*

### **FEATURES**

- *Brushless DC motor*
- *Integrated Soft start & MPPT*
- *Adjustable Speed and Timer control*
- *All Stainless Steel*
- *High Efficiency*
- *Remote switching*



*48-110V Solar Pump  
Controller*



*Solar Panel*

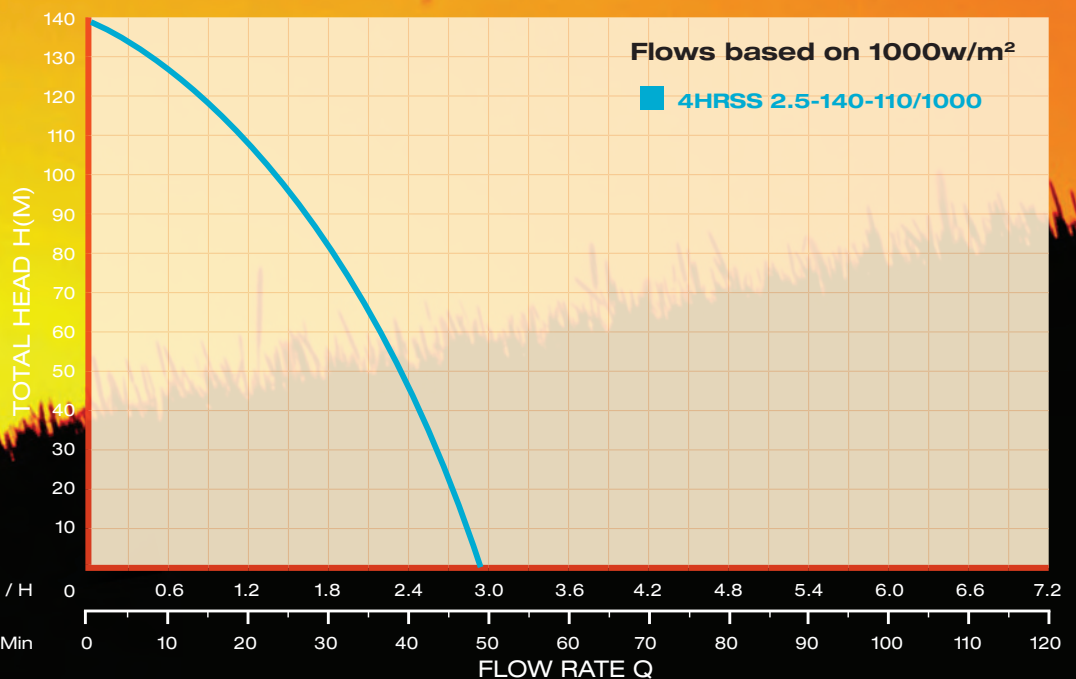



# WATERBOY 4HRSS Solar Pump

## PUMP END

Max flow rate	2.8m <sup>3</sup> /h
Max lift	140m
Operating temperature	-10°C — + 35°C

## SP CONTROLLER

Input voltage	• Nominal 48V DC
	Max open circuit—100 Voc
	• Nominal 110V DC
	Max open circuit—200 Voc
Timer adjustment	0—30 minutes
Speed control	Approx 30% flow reduction
Solar or Battery direct	

## MOTOR

Max power input	1400w
Max Submersion depth	40m
Lubrication	Oil filled

### Sand and Silt Tolerance

The pump (Helical Rotor) has a higher resistance to wear from sand, clay etc. than any other pump type. Continual sand and silt pumping will damage the pump. Do not use this unit to clean out dirty wells.

### Wire Sizes

Cable size must be calculated to stay within 4% power loss

### Temperature Limits

Pump end, motor: water temperature up to +35°C

Controller: ambient temperature -10°C to +50°C

### Warranty

Two years manufacturer's warranty against defects in material and workmanship, from date of installation.

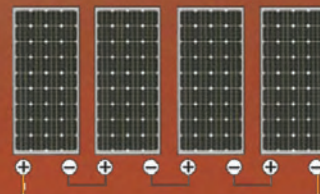

**48V Pump Connection**  
(Four pieces of 12V solar panels in series connection)

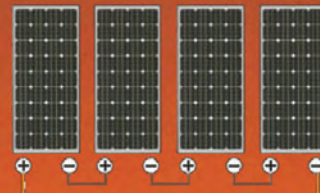

**110V Pump Connection**  
(Four pieces of 24V solar panels in series connection)

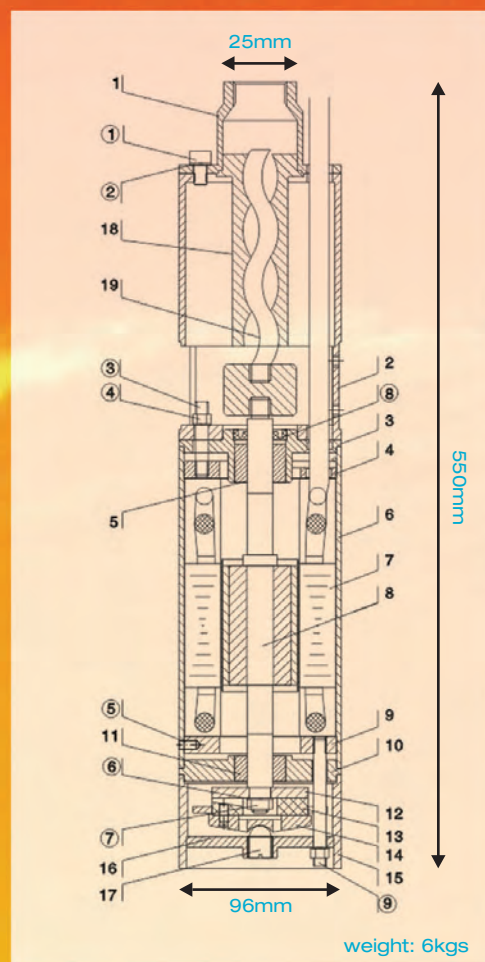

NO.	PART	NO.	PART
1	housing	15	pump base shell
2	suction inlet	16	pump base plate
3	bearing seat	17	adjust nut
4	cover	18	screw bush
5	bearing	19	screw
6	motor body	①	bolt
7	stator	②	spring washer
8	rotor	③	bolt
9	cover	④	hexagonal nut
10	bearing seat	⑤	key
11	bearing	⑥	spring washer
12	plate	⑦	hexagonal nut
13	oil lubricated bearing seat	⑧	head oil seal
14	bearing seat	⑨	studs